



# 承认书

## APPROVAL SHEET

客户:

CUSTOMER: \_\_\_\_\_

品名:

PARTNAME: \_\_\_\_\_ 铝电解电容器(E-CAP)

系列:

SERIES: \_\_\_\_\_ CD83H(RK) 系列

规格:

SPECIFICATION: \_\_\_\_\_ 见尺寸表

版本号:

VERSION: \_\_\_\_\_ QWH-11.001

日期:

DATE: \_\_\_\_\_ 2011.11.01

制 造 MANUFACTURE		客 户 CUSTOMER	
拟 制 FORMULATE	批 准 APPROVAL	检 验 CHECK	批 准 APPROVAL
谭进	技术部		



序号 No	目 录 INDEX	页 page
1	概述 SCOPE	4
2	订货方式 HOW TO ORDER	4
3	主要特性表 MAIN SPECIFICATIONS	5
4	产品结构 PRODUCT STRUCTURE	6
5	纹波电流频率因子 RIPPLE CURRENT FREQUENCY COEFFICIENT	8
6	尺寸表、允许纹波电流 DIMENSIONS AND RIPPLE CURRENT	9
7	包装 PACKING	10
8	贮存方法 STORAGE METHODS	10
9	其他说明 OTHERS	11



### 1. 概述 SCOPE

#### 1.1 概述 SCOPE

本承认书规定了铝电解电容器的技术规范。

This specification contains descriptions of the quality of aluminum electrolytic capacitors.

#### 1.2 参考标准 APPLICABLE SPECIFICATION

本承认书参考 JISC-5141 和 JISC-5102 制定。

This specification is made based on the Japanese Industrial Standard JISC-5141 Characteristics and JIS C-5102.

#### 1.3 工作温度范围 OPERATING TEMPERATURE RANGE

工作温度范围是电容器在施加额定工作电压条件下，可以长期可靠工作的环境温度范围。

Operating temperature range is the range of ambient temperature at which the capacitor can be operated continuously at rated voltage.

### 2. 订货方式 HOW TO ORDER

#### 2.1 订货方式 HOW TO ORDER

8	2	2	1	L	F	M	1	0	2	0	R	K	N	0	2	1	0
①	②	③	④	⑤	⑥	⑦	⑧	⑨	⑩								

代码 Code	产品类别 Type
8	成品 Product
1	素子 Element
2	裸品 Semifinished Product

代码 Code	电压 Voltage
LA	6.3
LB	10
LC	16
LD	25
LE	35
LF	50
LG	63
LH	80
MA	100
MB	160
MC	200
MJ	220
MD	250
MF	350
VA	400
VB	450
VC	500

代码 Code	尺寸 Dimensions $\Phi D \times L$ (mm)
0511	$\Phi 5 \times 11$
AA11	$\Phi 6.3 \times 11$
0812	$\Phi 8 \times 12$
1020	$\Phi 10 \times 20$
AB20	$\Phi 12.5 \times 20$

代码 Code	商标 Trademark
N	LH.NOVA

代码 Code	内码 Internal Code
21	125℃普通品
25	125℃凸台胶粒
2E	125℃平台胶粒 PET 胶管
2F	125℃凸台胶粒 PET 胶管

代码 Code	标称容量 Nominal Capacitance
R22	0.22uF
1R0	1uF
2R2	2.2uF
220	22uF
221	220uF
222	2200uF
223	22000uF

代码 Code	误差 Tolerance
J	±5%
K	±10%
V	± <sup>20</sup> / <sub>10</sub> %
M	±20%
Q	± <sup>30</sup> / <sub>10</sub> %
T	± <sup>50</sup> / <sub>10</sub> %
A	特殊

代码 Code	型号 Series
RK	CD83H

代码 Code	产品脚型 Lead Forming Type
0	散装品 Bulk
T	5mm 贴片编带品 5mm Chip tape
A	( $\Phi 4$ ~ $\Phi 6.3$ )2.5mm 脚距编带品; 2.5mm Tape
F	( $\Phi 4$ ~ $\Phi 8$ )5mm 脚距编带品; 5mm Tape
P	直径 $\Phi \geq \Phi 8$ mm 直脚方式编带品 original type(vertical) tape
M	5mm 成型剪脚品 5mm Lead forming
C	原脚距型成型剪脚品 C Lead forming
B	B 型成型剪脚品 B Lead forming
D	( $\Phi 4$ ~ $\Phi 5$ )2.5mm 成型剪脚品 Lead forming

代码 Code	胶管颜色 Sleeve Color
0	黑色 Black
1	深蓝色 Deep-blue
4	紫色 Purple
5	墨绿色 Black-green
7	棕色 Brown
9	绿色 Green



2.2 标记 MARKING

2.2.1 在电容器体上应注明如下内容 The following items shall be marked indelibly on the surface of capacitor:

- (1) 生产厂商商标 Manufacturer's name or trade mark. →
  - (2) 电容量 Capacitance. →
  - (3) 工作电压 Rated voltage. →
  - (4) 负极标志 Polarity of the terminals. →
  - (5) 上限工作温度 Maximum operating temperature. 示例 Sample: 125°C →
  - (6) 系列代码及容量偏差代码 Series Code & Capacitance tolerance Code →
- 示例 Sample:     RK                   (M)  
                          系列代码           容量偏差代码

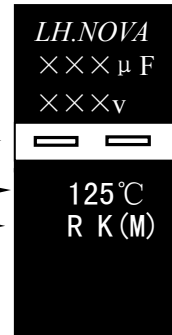

2.2.2 标记颜色 Marking color

套管颜色 Sleeve color: 黑色 Black.

标记颜色 Marking color: 银色 Argent.

3、主要特性表 MAIN SPECIFICATIONS

项目 Item	主要特性 Performance Characteristics								
额定工作电压范围 Rated Voltage Range	10~100V.DC	160~450V.DC							
使用温度范围 Operating Temperature Range	-40°C~+125°C	-25°C~+125°C							
标称静电容量范围 Nominal Capacitance Range	1~4700 $\mu F$	4.7~220 $\mu F$							
静电容量允许偏差 Capacitance Tolerance	$\pm 20\%$ (M, +20°C, 120Hz)								
漏电流 Leakage Current (20°C)	额定工作电压(V) Rated working voltage	10~100	160~450						
	漏电流 Leakage current	2 分钟后 $I \leq 0.01CV$ 或 $3(\mu A)$ , 取 最大值 After 2 min. $I \leq 0.01CV$ or $3(\mu A)$ , Whichever is greater.	2 分钟后 $I \leq 0.03CV+25(\mu A)$ After 2 min. $I \leq 0.03CV+25(\mu A)$						
C: 标称静电容量 ( $\mu F$ ) Nominal Capacitance in $\mu F$									
V: 额定工作电压 (V) Rated working voltage in V									
损耗角正切 DF Dissipation Factor	额定工作电压(V) Rated working voltage	10	16	25	35	50	63	100	160~450
	DF(MAX) (20°C, 120Hz)	0.35	0.22	0.20	0.17	0.15	0.12	0.10	0.15

项目 Item	主要特性 Performance Characteristics													
浪涌电压 Surge Voltage	额定工作电压(V) Rated working voltage	10	16	25	35	50	63	100	160	200	250	350	400	450
	浪涌电压(V) Surge voltage	13	20	32	44	63	79	125	200	250	300	400	450	500
温度特性 Temperature Stability	额定工作电压(V) Rated working voltage		10	16	25	35	50	63	100	160~250	350~450			
	阻抗比(120Hz) Impedance Ratio	z-25°C/z+20°C	4	3	2	3	3	3	3	3	3	6		
		z-40°C/z+20°C	6	6	4	3	3	3	3	3	--	--		
高温负荷特性 Load life	<p>在+125°C 环境中施加额定工作电压和最大允许纹波电流 2000 小时后,电容器的性能符合下面要求:</p> <p>After application of rated working voltage with max permissible ripple current specified at +125°C for 2000 hours, capacitors meet the characteristics requirements measured at +20°C listed at below:</p> <p>1、电容量变化率:±20%初始测量值以内 Capacitance change : ±20% initial measured value</p> <p>2、漏电流: ≤初始规定值 Leakage current: ≤initial specified value</p> <p>3、损耗角正切值≤200%倍初始规定值 Dissipation factor: ≤200% initial specified value</p>													
高温贮存特性 Shelf life	<p>在+125°C环境无负荷放置 1000 小时后, 电容器的性能符合高温负荷特性中所列的规定值</p> <p>After leaving capacitors under no load at +125°C for 1000 hours, capacitors meet the characteristics listed above.</p>													

#### 4. 产品结构 PRODUCT STRUCTURE (mm)

##### 4.1 外形尺寸 SHAPE AND DIMENSIONS

β	±0.5			±1.0			
ΦD	5	6.3	8	10	12.5	16	18
F±0.5	2.0	2.5	3.5	5.0		7.5	
Φd±0.1	0.5		0.6			0.8	
L	11		12,16	12,16,20	16,20,25	16,20,25,30,35	20,25,30,35,40
	L≤16: L±1.5; L>16: L±2.0						

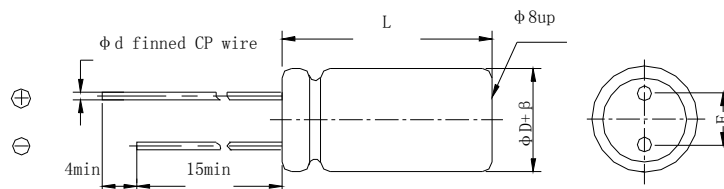



4. 1. 1 内部构造图及构成材料 INTERNAL CONSTRUCTION AND COMPONENTS

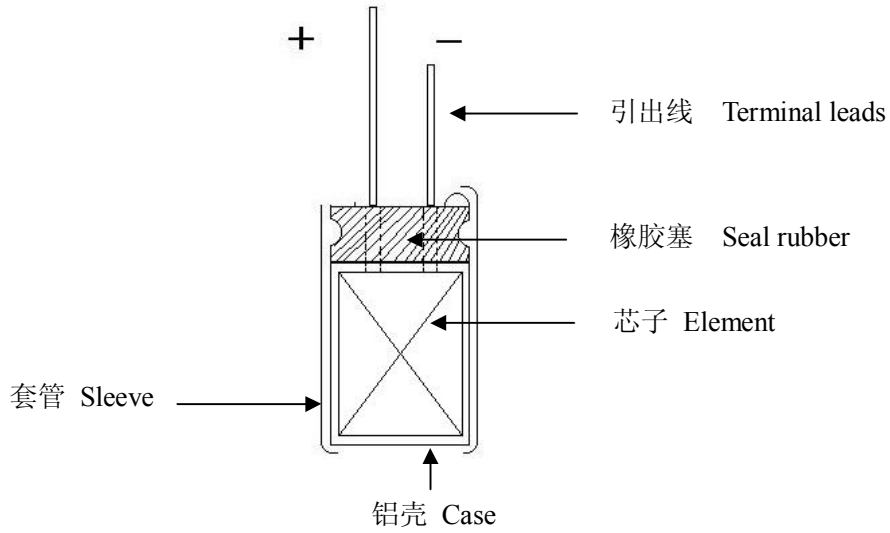

芯子分解图 Dicomposing figure of clement

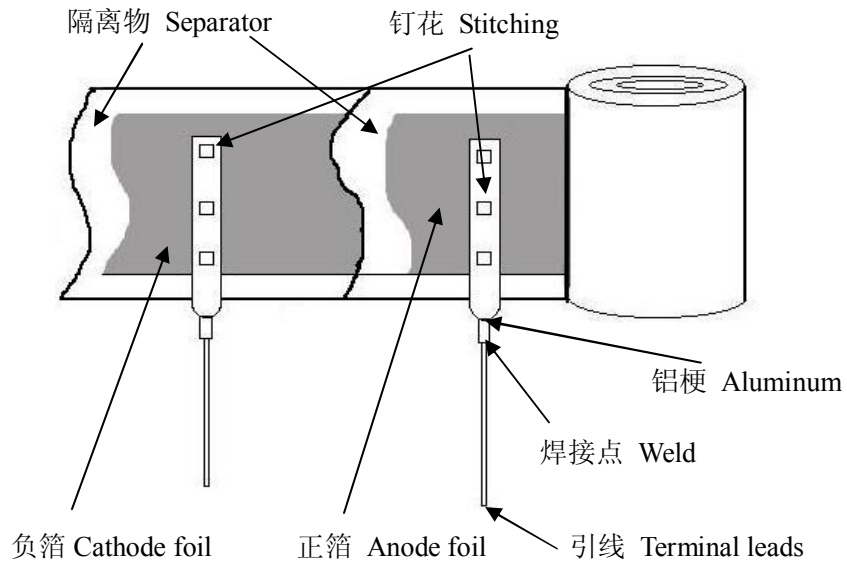

序号 Components	材料.规格.处理 Materials.Finish/Specification	序号 Components	材料.规格.处理 Materials.Finish/Specification
1 铝壳 Case	铝 Aluminum	5 隔离物 Separator	电解纸 Paper
2 套管 Sleeve	胶管 Sleeve	6 正箔 Anode foil	高纯铝 Fine Aluminum
3 封口塞 Seal	合成橡胶 Synthesized rubber	7 负箔 Cathode foil	铝 Aluminum
4 引线 Terminal lead	CP 线(铁+锡) CP wire (Fe+Sn)	8 电解液 Electrolyte	有机溶剂 Organic Solvent etc



4.2 引线编带 TAPING METHOD (mm)

A 型 A Taping

F 型 F Taping

P 型 P Taping

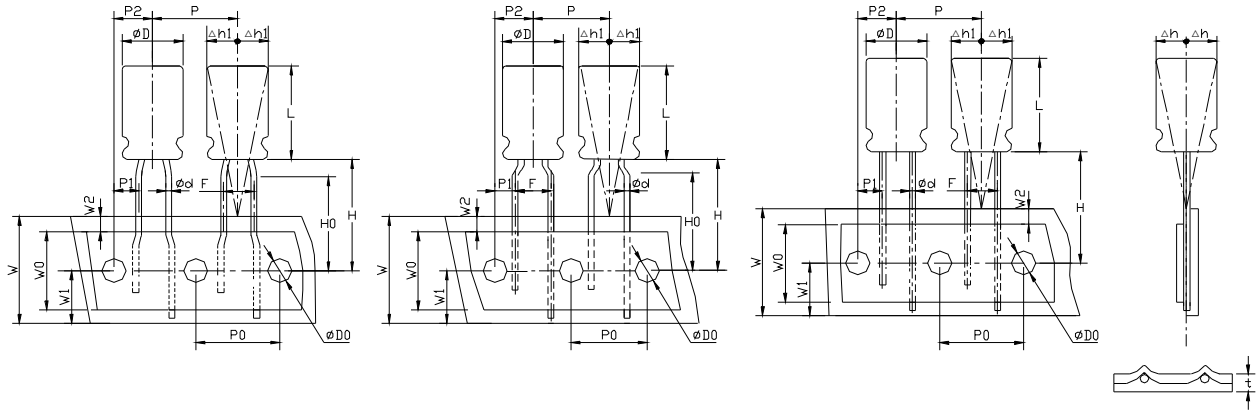

外径 Case Dia 项目及误差 Item Tolerance	Φ4	Φ5	Φ6.3	Φ4	Φ5	Φ6.3	Φ8	Φ8	Φ10	Φ12~Φ13	Φ16~Φ18
L+2max	5~16		5~16			7~20	7~20	9~20	16-25	16-25	
代码 Taping code	A			F			P				
Φd±0.05	0.45~0.50		0.45~0.50			0.60	0.60	0.60	0.8		
P±1.0	12.70		12.70			12.70	15.0	30.0			
P <sub>0</sub> ±0.2	12.70		12.70			12.70	15.0	15.0			
P <sub>1</sub> ±0.5	5.10		3.85			4.60	3.85	5.00	3.75		
P <sub>2</sub> ±0.5	6.35		6.35			6.35	7.50				
F± <sup>0.5</sup> <sub>0.2</sub>	2.50		5.00			3.50	5.00±0.5	7.5±0.5			
H±0.5	18.5										
H <sub>0</sub> ±0.5	16.5	-	16.5			-					
W±0.3	18.00										
W <sub>0</sub> min	10.00										
W <sub>1</sub> ±0.5	9.00										
W <sub>2</sub> max	3.00										
ΦD <sub>0</sub> ±0.2	4.00										
Δh max	0.50										
Δh <sub>1</sub> max	0.50										
t±0.2	0.60										

5. 纹波电流频率因子 RIPPLE CURRENT FREQUENCY COEFFICIENT

Freq (Hz)	50 (60)	100 (120)	1K	10K	≥100K	
WV(V)	6.3~100	0.20	0.45	0.70	0.80	1.00
	160~450	0.25	0.50	0.80	0.90	1.00



6. 尺寸表、允许纹波电流 DIMENSIONS AND RIPPLE CURRENT (RK)

WV/V Cap/μF	10(LB)		16(LC)		25(LD)		35(LE)		50(LF)		63(LG)		100(MA)	
	(1)	(2)	(1)	(2)	(1)	(2)	(1)	(2)	(1)	(2)	(1)	(2)	(1)	(2)
1(1R0)									8×12	35				
2.2(2R2)									8×12	50				
3.3(3R3)									8×12	70				
4.7(4R)									8×12	100			8×12	100
10(100)									8×12	200			8×12	200
22(220)									8×12	260			8×12	220
33(330)									8×12	300	8×12	250	10×12	260
47(470)									8×12	300	10×12	400	10×16	330
100(101)							8×12	360	10×12	520	10×16	450	12.5×20	670
220(221)					8×12	360	10×12	620	10×20	890	12.5×20	820	16×25	1100
330(331)	8×12	360	8×12	360	10×12	620	10×16	800	12.5×20	1000	12.5×25	1000	16×31	1300
470(471)	10×12	620	10×12	620	10×16	800	10×20	960	12.5×25	1200	16×25	1500	18×30	1600
1000(102)	10×20	960	10×20	960	12.5×20	1100	12.5×25	1430	16×30	2180	16×30	1850		
2200(222)	12.5×25	1430	12.5×25	1430	16×30	2300	16×35	2550	18×40	2800	18×40	2350		
3300(332)	16×25	1900	16×30	2300	16×35	2550	18×35	2800						
4700(472)	16×30	2300	16×35	2550										

WV/V Cap/μF	160(MB)		200(MC)		250(MD)		350(MF)		400(VA)		450(VB)		
	(1)	(2)	(1)	(2)	(1)	(2)	(1)	(2)	(1)	(2)	(1)	(2)	
4.7(4R7)									10×16	180	10×20	150	
6.8(6R8)								10×16	220	10×16	220	12.5×20	320
10(100)	10×16	250	10×16	250	10×20	280	10×20	280	10×20 12.5×20	280	16×25 18×20	560	
22(220)	10×20	500	10×20	500	12.5×20	600	12.5×20	350	12.5×25 16×20	430	16×30 18×25	700	
33(330)	10×20	500	12.5×20	600	12.5×20	600	16×20	500	16×25 18×20	640	18×30	880	
47(470)	12.5×20	660	12.5×20	660	12.5×25 16×20	720	16×25 18×20	660	16×30 18×25	840			
68(680)	12.5×25 16×20	760	12.5×25 16×20	760	16×25 18×20	920	16×30 18×25	850	18×30	1000			
100(101)	16×25 18×20	1120	16×25 18×20	1120	16×30 18×25	1200							
150(151)	16×30 18×25	1360	16×30 18×25	1360	18×30	1500							
220(221)	16×30 18×25	1400	18×30	1700									

(1) 外形尺寸 Case Size D×L(mm)

(2) 最大允许纹波电流 Max allowable ripple current (mA rms +125°C,100KHz)

6.1 客户料号与风华物料对照表 Customer P/N and Fenghua P/N collate list

客户 P / N	风华 P / N
--	8470LFM0812RKN0210
	8101LEM0812RKN0210
	8221LEM1012RKN0210
	8102LBM1020RKN0210

## 7. 包装 PACKING

### 7.1 包装标签 PACKING LABEL

规格、尺寸  
Specification and dimensions

批号的填写 LOT:

1 2 3 4 5 6 7 8 9 10 11 12 13 14

类别 年份 月份 日期 区别号  
Sort Year Month Date Discriminate mark

流传单号码  
Sequence number

### 7.2 编带产品按下图包装

Taped capacitors are packed into carton, according to the following drawing.

ΦD	Qty. (Pcs)	L(电容高度)≤22mm	L(电容高度)=25±2mm
		L×W×H(mm)	L×W×H(mm)
Φ5	2000	330×50×240	330×60×240
Φ6.3	1500		
Φ8	1000		
Φ10	600		
Φ12.5	340		
Φ16	250		
Φ18	200		

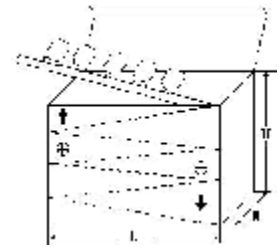

### 7.3 散包装按下图包装方式

Bulk packing capacitors are packed into PVC bag, inner box and carton according to the following drawings.

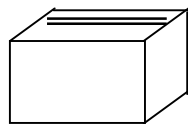

内盒  
inner box

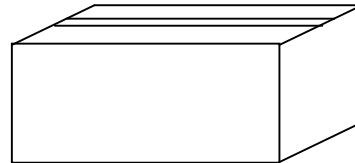

外箱  
carton

### 7.4 散装、编带品外包装箱不干胶标签，实用尺寸为 167.5mmX97.5mm。

The dimension of the label on the carton is 167.5mmX97.5mm

## 8. 贮存方法 STORAGE METHODS

保存期限：1 年，如果没有其他规定，标准的测试、检验环境条件如下所示：

环境温度：5 至 35℃；相对湿度：45 至 85%；大气压力：86kpa 至 106kpa。

如果对测试结果有异议，可以在以下条件测试：

环境温度：20±2℃；相对湿度：60 至 70%；大气压力：86kpa 至 106kpa。



Storage life: 1 year, Unless otherwise specified, the standard range of atmospheric conditions for making measurements and tests are as follows.

Ambient temperature: 5 to 35°C Relative humidity: 45 to 85% Air pressure: 86kpa to 106kpa.

If there may be doubt on the results, measurements shall be made within the following limits.

Ambient temperature: 20±2°C Relative humidity: 60 to 70% Air pressure: 86kpa to 106kpa.

## 9. 其它说明 OTHERS

### 9.1 铝电解电容器使用注意事项 Important information on the application of aluminium electrolytic capacitors

#### (1).直流铝电解电容器应按正确的极性使用 DC electrolytic capacitors are polarized

当直流铝电解电容器被反极性接入电路时, 电容器会导致电子线路短路, 由此产生的电流会引致电容器损坏。若电路中有可能在负引线施加正极电压, 请选用无极性产品。

When reverse voltage is applied on DC electrolytic capacitor, the capacitor will become short-circuited please use non-polarized capacitors in the circuit or the capacitor will be damage due to abnormal current flows through the capacitors since the circuit where the positive voltage may be applied to the cathode terminal.

#### (2).在额定工作电压以下作用 Use capacitor within rated voltage

当电容器上所施加电压高于额定工作电压时, 电容器的漏电流将上升, 其电气特性将在短时期内劣化直至损坏。请注意电压峰值勿超出额定工作电压。

When capacitor is used at higher voltage than the rated voltage, leakage current increases, characteristics drastically deteriorate and damage in a short period may occur as a result. Please take extra caution that the peak voltage should not exceed the rated voltage.

#### (3).作快速充放电使用 Charge and discharge application.

当常规电容器被用作快速充电用途。其使用寿命可能会因为容量下降, 温度急剧上升等而缩减

When aluminum electrolytic capacitors for general purpose are employed in rapid charge and discharge application, its life may be shorted by capacitance decreasing, heat rising, etc.

#### (4).电容器贮存 Store the capacitor.

当铝电解电容器作了长期贮存后, 其漏电流通常升高, 贮存温度愈高, 漏电流上升愈快。因此应注意贮存环境的选择, 在电容器上施加电压后, 漏电流值将不断下降, 在铝电解电容器的漏电流值上升对电路有不良影响的, 请在使用前充电处理。

I creased leakage current is common in aluminum capacitors which have been stored for long period of time. The Higher the storage temperature, the higher the leakage current increase, therefore please take precautions concerning the storage location. The leakage current decreases gradually as voltage is applied to the capacitor. In cases where increased leakage current causes problems in the circuit, apply voltage (aging) before using.

#### (5).施加纹波电流应小于额定值 Ripple current applied to capacitor should not exceed the rated value.

施加纹波电流超过额定值后, 会导致电容器体过热, 容量下降, 寿命缩短。所施加纹波电压的峰值应小于额定工作电压。

Excessive heat will reduce capacitance and result in shortened life of capacitor if ripple currents exceeding the specified rated value are applied. The peak value of the ripple voltage should be less than the rated voltage.

#### (6).使用环境温度 Ambient temperature.

铝电解电容器的使用寿命会受到环境温度的影响。据科学统计, 使用环境温度下降 10°C 其使用寿命增加 1 倍。

Its ambient temperature closely affects the life of an aluminum electrolytic capacitor. It is generally stated, that life doubles for each 10°C decrease in temperature.

#### (7).引出线强度 Lead stress

当拉力施加到电容器引出线, 该拉力将作用于电容器内部, 这将导致电容器内部短路, 开路或漏电流上升。在电容器焊装到电路板, 请勿强烈摇动电容器。

When a strong force is applied to the lead wires or terminals, stress is put on the internal connections. This may result in short circuit, open circuit or increased leakage current. It is not advisable to bend or handle a capacitor after it has been soldered to the PCB board.

#### (8).焊接过程耐热性 Heat resistance at the soldering process

铝电解电容器装至电路板进行浸焊或波峰焊时, 其塑料套管可能因焊接时间过长、温度过高而发生破裂或二次收缩。

In the dip soldering process of PCB board with aluminum electrolytic capacitors mounted, secondary shrinkage or crack of PVC sleeve may be observed when solder temperature is too high or dipping time is too long.

#### (9).电路板的安装孔距及安装位置 Hole pitch and position of PCB board.

电路板安装孔的设计应与产品说明书的引线脚距相一致, 如果将电容器强行插入孔距不配套的电路板, 那么会有应力作用于引出线, 这将导致短路或漏电流上升。

PCB board must be designed so its hole coincides with the lead pitch (lead spacing) of the capacitor specified by the catalog or specifications. When a capacitor is forcibly inserted into an unmatched hole, a stress is put on the leads. This could result in a short circuit or increased leakage current.

### 9.2 本产品不含铅、镉等元素 This product does not include Plumbum or Cadmium.